

PRECISION BAROMETER WITH NMEA OUTPUT

BAR20-N



DESCRIPTION

This USB-connected barometer allows for precise measurement of atmospheric pressure (1 to 120 kPa). Thanks to the use of a high resolution ADC (24-bit), very small changes in atmospheric pressure can be sensed and sent to a computer over USB. The BAR20-N appears as a serial port (Virtual COM port) and outputs atmospheric pressure at 1-second intervals using MDA and XDR NMEA sentences. Designed as a compact USB-Key form factor for easy integration even in space-constrained applications.

APPLICATIONS

- Navigation (air, sea, etc.)
- Altitude measurement
- Meteorological measurement
- Research & development
- Engineering and R&D
- Education
- Aeronautic

INSTALLATION TIME

Less than 10 minutes

UNIQUE SERIAL NUMBER

Each unit is assigned a unique serial number allowing for traceability and certification

FREE DAQ SOFTWARE

This product isn't supported by our free DAQ software

DATA INTEGRATION

Command-line tools for direct data access and integration

SPECIFICATIONS

Parameter	Condition	Value	Units
Atmospheric pressure			
Operating temperature range	–	-40 to 70	°C
Operating pressure range	For full accuracy	45 to 110	kPa
Extended pressure range	Linear range of ADC	1 to 120	kPa
ADC resolution	–	24	bits
Response time	Interval	1	s
Factory calibrated	Individually ^[2]	Yes	–
Filter	–	2 nd order	–
Noise	–	±0.0012	kPa
Accuracy	At 25°C 70 to 110 kPa	±0.15	kPa
Accuracy	0 to 50°C 45 to 110 kPa	±0.2	kPa
Accuracy	-20 to 85°C 45 to 110 kPa	±0.35	kPa
Accuracy	-40 to 85°C 45 to 110 kPa	±0.6	kPa
Long-term stability	At 25°C	±0.1	kPa/yr
Internal temperature			
Range	–	-40 to 70	°C
Resolution	Typ.	0.01	°C
Accuracy	Typ.	0.8	°C
Accuracy vs. external temperature	Typ., at 25°C	+3	°C

SPECIFICATIONS

Parameter	Condition	Value	Units
Power supply			
Voltage	Powered through a USB port	5	V
Current consumption	At 5V	≤ 22	mA
Mechanical			
Dimensions	See drawing below	–	–
Colour	–	Black	–
Weight	–	6	g
Housing			
Temperature operating range	–	-40 ^[1] to 85	°C
Humidity operating range ^[3]	Non-condensing	10 to 90	%RH
Material	–	ABS	–
IP rating	–	50 ^[3]	–
Form factor	–	USB-key	–
Miscellaneous			
Communication	USB, virtual COM port ^[4]		
ADC resolution	–	24	bits
Temperature compensated	By the manufacturer	Yes	–
Lifetime	–	5	years
Certification(s)			
RoHS	RoHS3	Yes	–
CE	CE/REACH	Yes	–

Warning: This product should not be used in applications where its failure may cause personal injury.

Note: While every effort has been made to ensure accuracy in this publication, no responsibility can be accepted for errors or omissions.

Note: Data may change without notification, and you are strongly advised to obtain copies of the most recently issued datasheet.

***The BAR20-N is not supported by our free data acquisition tools.**

Works natively (no drivers to install) under Windows 10 and Linux (ttyACM)^[5].

Supported by navigation software such as OpenCPN and Expedition^[6]

Simple ASCII output, interfaces easily with most programming languages.

The XDR (transducer measurement) sentence provides pressure in Bars.

The MDA (meteorological composite) sentence provides pressure in Inches of mercury and in Bars.

^[1] Only if the sensor is not moved while the temperature is below 0°C.

^[2] Each sensor is individually conditioned by the manufacturer of the semiconductor sensor chips, in the best stable conditions and their correction coefficients are recorded in each of them.

^[3] If water condensation or splashing is possible, it is recommended to install the probe pointing down to reduce the risk of water build-up in the sensor. If water splashing is possible, protect the sensor and the cable converter using extra precautions. Extra housing may be required depending on the application.

^[4] Microsoft Windows 7 does not support the virtual COM port and therefore does not recognize this product.

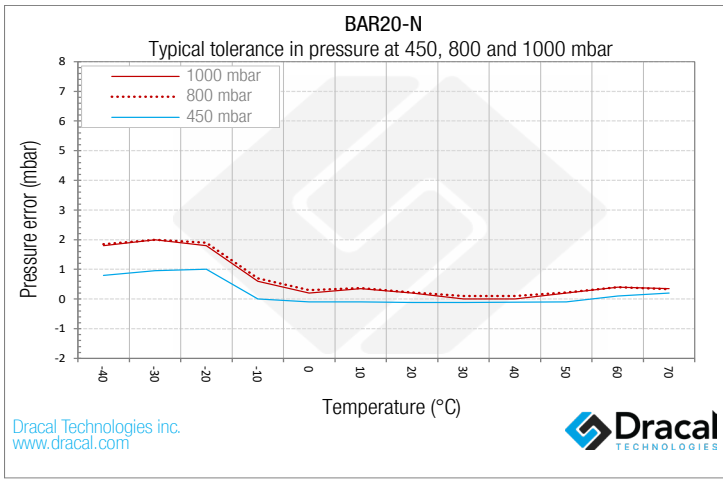

PLEASE NOTE: The BAR20-N is not supported by our free data acquisition tools.

Example of the product output:

```
$YXXDR,P,1.012060,B,USB-BAR20-N*1e
$YXMDA,29.886112,I,1.012060,,,,,,,,,,,,,*3b
```

PLEASE NOTE: Microsoft Windows 7 does not support the virtual COM port and therefore does not recognize this product.

ABSOLUTE PRESSURE ACCURACY AFTER CALIBRATION 2ND ORDER COMPENSATION

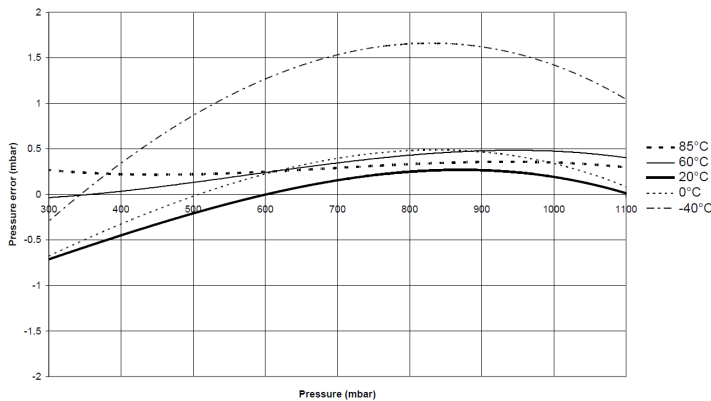

PRODUCT DIMENSIONS

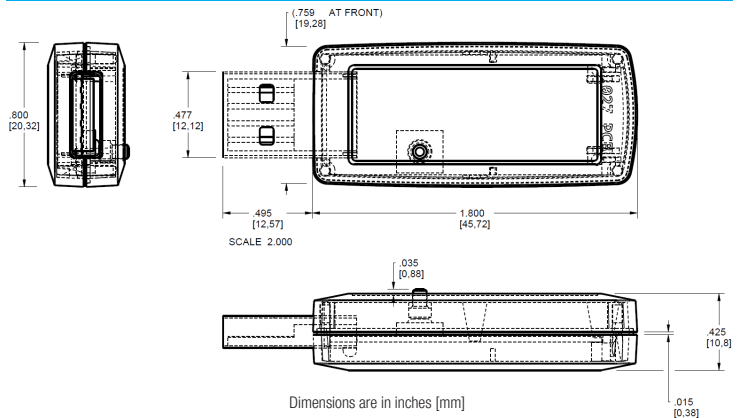

CAUTION: Please keep in mind that electromagnetic interference (EMI) may decrease the accuracy of the sensor. Avoid using this device near EMI sources such as motors, high voltage transformers and fluorescent tubes.

NOTE: Note that this product is not waterproof and requires protection if contact with water is possible.

TIP: The barometer is very sensitive to air pressure. The use of a USB extension cable may increase the barometer precision if you intend to read small variations of pressure. If you directly plug the barometer to a PC, remember that through the USB connector, a small pressure or vacuum from the PC fan(s) may slightly deviate your readings.

TIP: Avoid installing the sensor in a location where strong vibration is likely to occur. Strong vibrations may cause slight inaccuracies in the reading.

TIP: Keep in mind that airflow around the unit may cause a variation of pressure. Avoid placing the unit in a windy environment. One solution may be to place the barometer in a ventilated housing to reduce the air flow.

TIP: As for any precision measurement equipment, it is advised to power on the unit at least 10 minutes before using it.

IMPORTANT: The BAR20-N is not supported by our free data acquisition tools.

ORDERING

PRODUCT(S)

PART NUMBER	OPTION	DESCRIPTION
601027	USB-BAR20-N	Precision Barometer with NMEA output